

# CORE-70

## MANUAL

RFID Long Range Reader

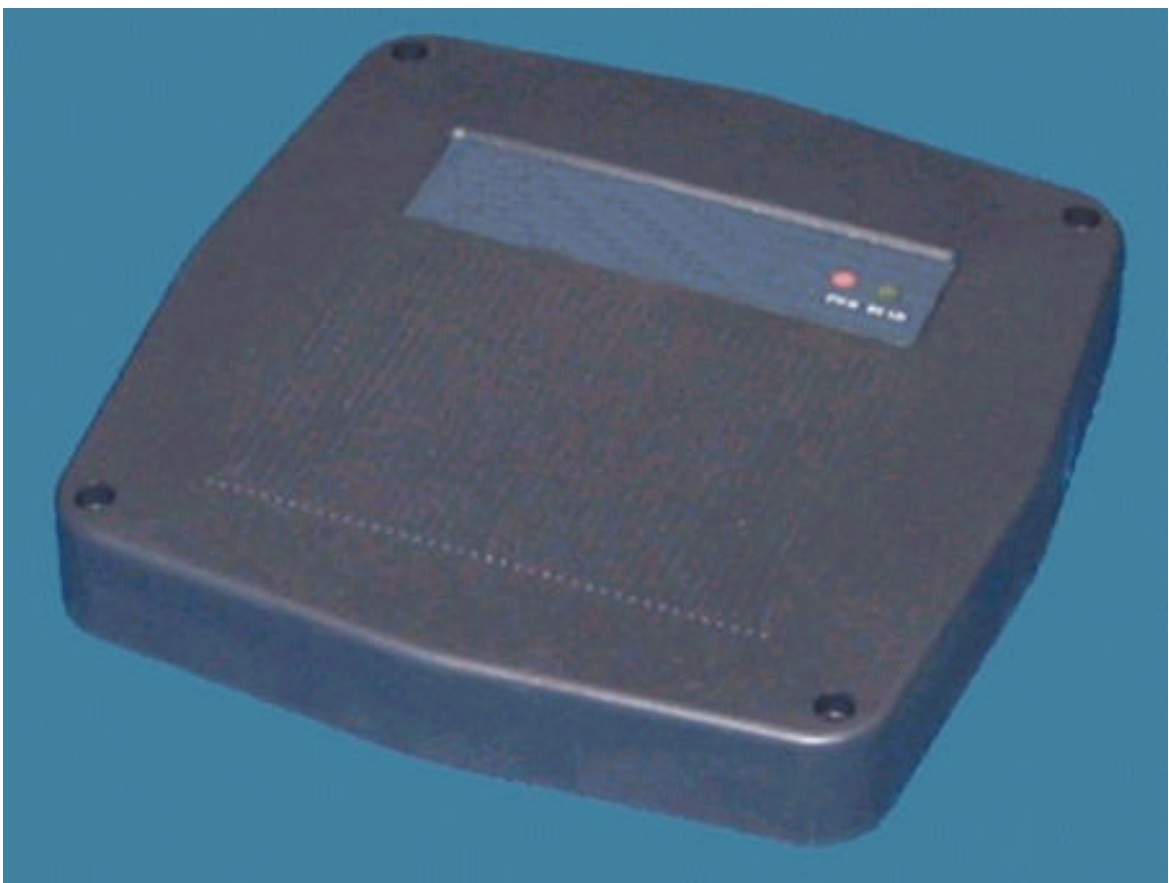

*Advanced Reader Development*  
Advanced Digital Reader Technology

Manual Rev 0.1

## **PRODUCT DESCRIPTION**

---

### Introduction

The CORE-70 is an advanced reader for the popular EM4102 format 125KHz tags. Read ranges of over 70 cm are possible with ISO cards. Advanced features include auto-tuning and DSP capabilities to increase read range and to reduce unwanted vibration and interference. The CORE-70 also features RS232, Wiegand26, and Wiegand34 output formats. Furthermore, the reader is encapsulated for environmental protection. The CORE-70 provides solutions for long-range RF reader applications such as car parks and other hands free use.

### Features

- Very Long Read Range
- Digital Signal Processing
- Remote Auto-Tuning
- Strong Water Resistant Enclosure

### Features Description

DSP (Digital Signal Processing) is used to provide superior range and reduce vibration and electrical

noise effects. These effects are not eliminated so care should still be taken to position the equipment away from sources of electrical noise and vibration.

Temperature changes can affect accuracy of the antenna tuning. The CORE-70 is equipped with a sophisticated self-tune facility or auto-tune. The reader performs an auto-tune shortly after power-up and every 10 minutes thereafter.

### Installation

Position the CORE-70 away from sources of interference such as main wiring. Do not fix the reader antenna on solid steel objects or range loss will occur and the auto-tuning may even run out of range. Moderate metal fixtures are acceptable. Computer monitors used in DOS mode can result in powerful interference especially when older monitors are used. Vibration can also cause loss of range.

## SPECIFICATIONS

Table 1. CORE-70 Operational & Physical Characteristics

Parameter	Conditions
Power Requirements	12V DC
Current Consumption	0.2 Amperes nominal
Frequency	125 KHz
Read Range	Over 70 cm with ISO cards
Interfaces	RS232 (9600, n, 8, 1) and Wiegand26/34
Transponder	Read-only 64 bits, Manchester encoded
Auto-tune	Internal upon switch-on and every 10 minutes
Read Indication	LED and RS232 connection
Dimensions	230mm x 230mm x 35mm
Nominal Weight	1.0 Kg

## DATA FORMATS

### Output Data Structure – ASCII

STX (02h)	DATA (10 ASCII)	CHECKSUM	CR	LF	ETX (03h)
-----------	-----------------	----------	----	----	-----------

The checksum is the result of the XOR of the 5 binary Data bytes (the 10 ASCII data characters)

### Output Data Structure – Wiegand26

1	2	3	4	5	6	7	8	9	10	11	12	13	14	15	16	17	18	19	20	21	22	23	24	25	26	
P	E	E	E	E	E	E	E	E	E	E	E	E	O	O	O	O	O	O	O	O	O	O	O	O	O	P
Even parity (E)													Odd parity (O)													

P = Parity start bit and stop bit

### Output Data Structure – Wiegand34

1	2	3	4	5	6	7	8	9	10	11	12	13	14	15	16	17	18	19	20	21	22	23	24	25	26	27	28	29	30	31	32	33	34	
P	E	E	E	E	E	E	E	E	E	E	E	E	E	E	E	O	O	O	O	O	O	O	O	O	O	O	O	O	O	O	O	O	O	P
Even parity (E)																	Odd parity (O)																	

P = Parity start bit and stop bit

### Report Format

Upon switch-on the reader sends a report via the RS232 line. The report indicates the Software Revision and the Tuning Variable. A typical report will be as follows (hex values):

Day	Month	Year	Revision #	Tune Variable	Checksum
01	01	01	08	04	45

The Tune Variable indicates the Tuning Capacity. A figure between 01h-0Dh is OK. A figure outside this range can be caused by environmental demands, possibly due to fixing directly onto sheet steel.

## REFERENCE DATA

Table 2. Cable Signal Definitions

Pin no. (internal)	Wire color	Signal	Description
1	Red	PWR	+12V DC input
2	Black	GND	Ground
3	NA (exposed)	Shield	Connect to Ground
4	Violet	Unused	Reserved for future use
5	Blue	RS232	Serial RS232 output (9600, n, 8, 1)
6	Brown	Data 0	Data 0 line for Wiegand output *
7	Green	Data 1	Data 1 line for Wiegand output *
8	Orange	CP	Card Present
9	Yellow	PRGM	Program line (format selector)

\* Add 1.5k pull-up resistors for Data0 and Data1 signals

Table 3. Output Format Programming

Output Format	Programming
RS232	Connect PRGM (Yellow wire) to RS232 (Blue wire)
Wiegand26	Connect PRGM (Yellow wire) to GND (Black wire)
Wiegand34	Connect PRGM (Yellow wire) to PWR (Red wire)

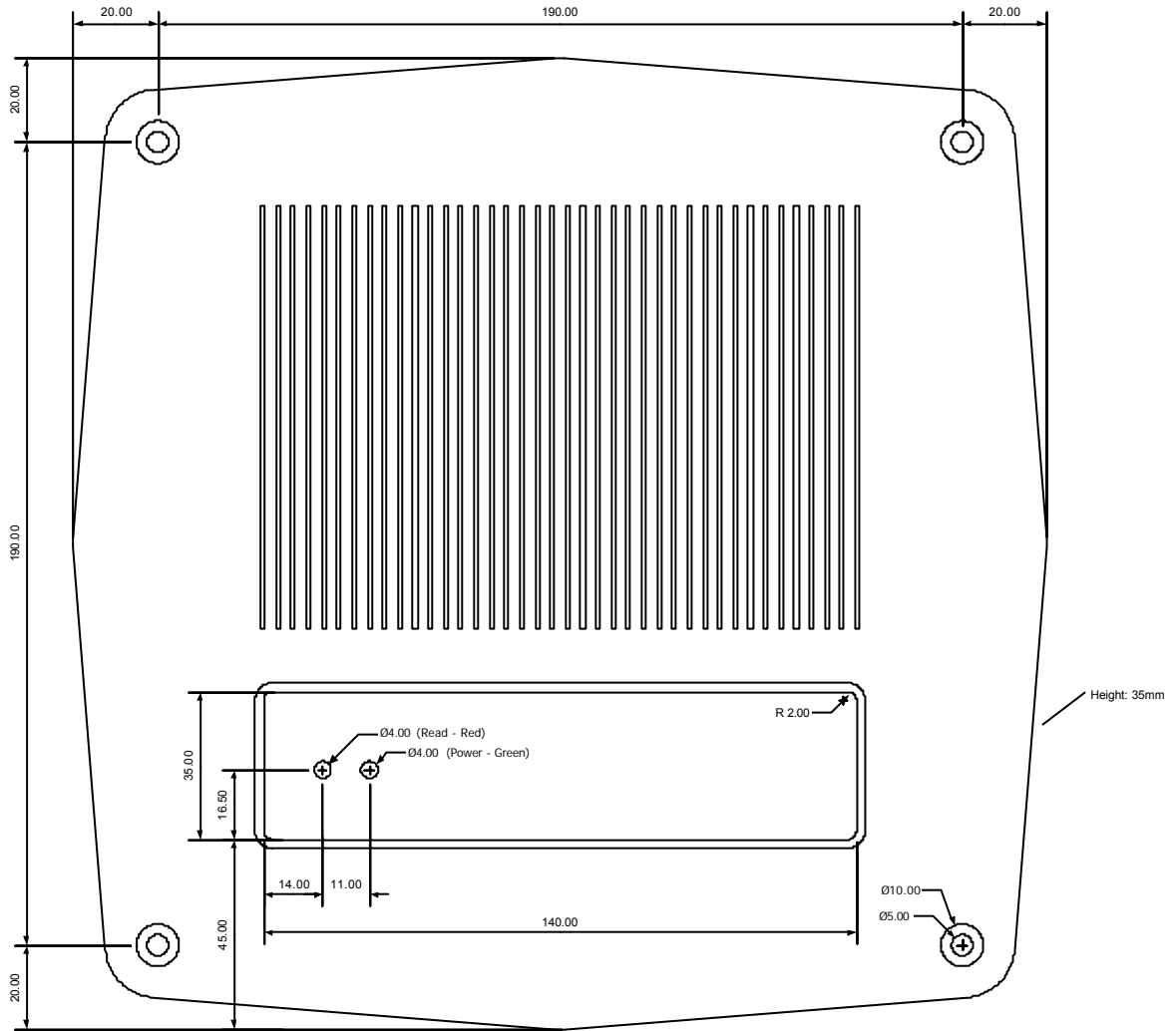

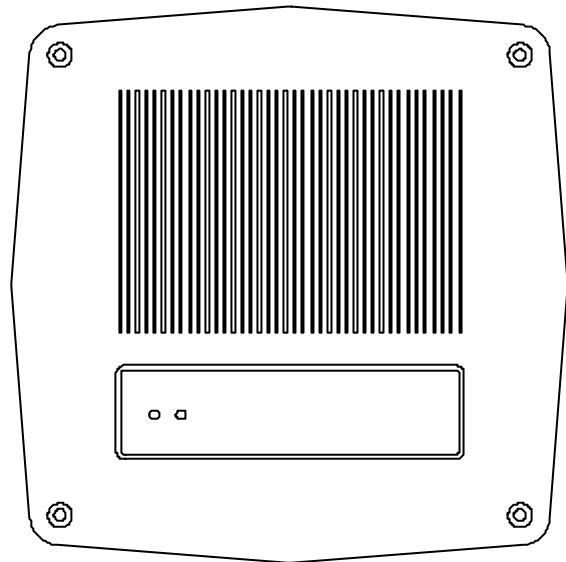
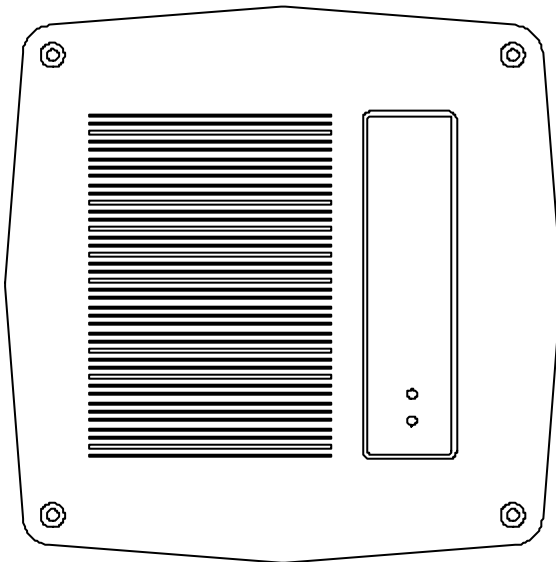
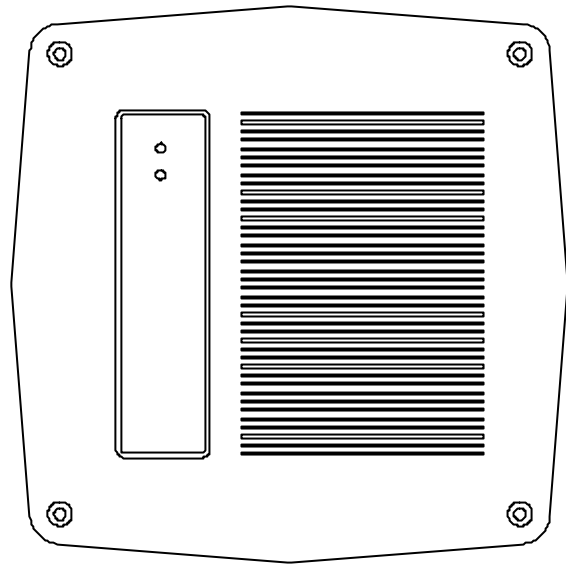
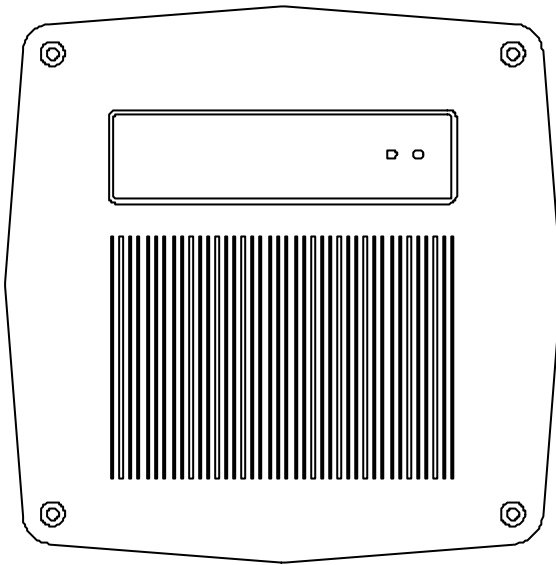

*Specifications subject to change. ARD reserves the right to change its products and the specifications given here at any time without notice.*

**Advanced Reader Developments**  
Advanced Digital Reader Technology

**For OEM and Technical Support  
Please Contact**

CoreRFID Ltd. Dallam Court, Dallam Lane, Warrington, WA2 7LT  
Tel: +44 (0)845 071 0985 Fax: +44 (0)845 071 0989 Email: info@coreRFID.com